

Electric Submersible Pumps

NEW: HSD SERIES SAND PUMP

New Super HSD Durable Sand Pump

Pump sand, solids and debris with minimal wear and clogging.

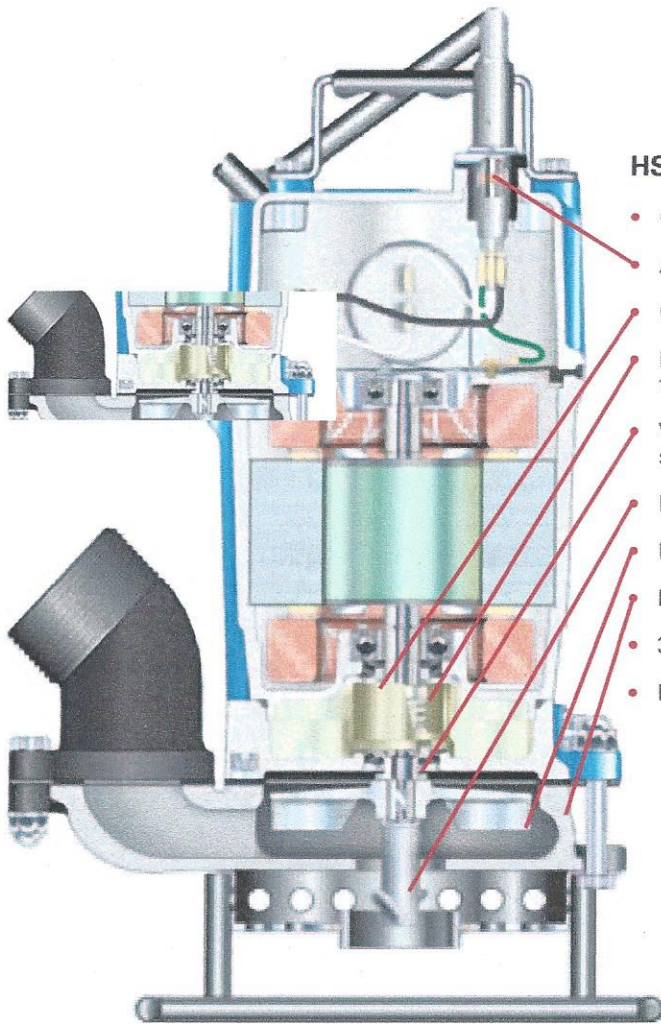

HSD Series Features

- Complete special 2 years warranty including wear.
- Anti-wicking block prevents water incursion.
- Oil Lifter extends seal life by ten times.
- Double Inside Mechanical Seal with silicon carbide faces provides the longest operational life of any seal available.
- V-Ring Seal Protector protects mechanical seal from abrasive particles.
- Built-in larger shaft mounted agitator suspends solids.
- High Chromium Iron impeller.
- Ductile Iron Casing.
- 3/4 HP motor; stronger than HS2.4S-62.
- Easy pump end disassembly by removing only 3 nuts.

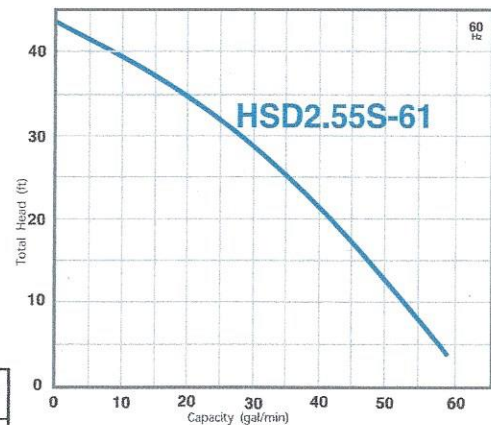

Model	Discharge Bore (inch)	Ship Weight (lb.)	Cable Length (ft.)	Dimensions (inch)		Continuous Running Water Level (inch)
				Diameter	Height	
HSD2.55S-61	2	33	16	6 3/8	15 3/8	4 1/8